

**Specifications**

Nominal Voltage		12 V
Capacity (25°C)	20HR(10.5V)	200 Ah
	5HR(10.2V)	156 Ah
	1HR(9.6V)	116Ah
Dimension	Length	522 ± 2mm (20.55inch)
	Width	238 ± 2mm (9.37inch)
	Height	222 ± 2mm (8.74inch)
	Total Height	222 ± 2mm (8.74inch)
Approx. Weight		66 kg (145.2lbs) ± 2%
Terminal type		T11
Internal resistance (Fully charged, 25°C)		Approx. 3.3m Ω
Capacity affected by temperature (10HR)	40°C	103%
	25°C	100%
	0°C	88%
	-15°C	70%
Self-discharge (25°C)	3 month	Remaining Capacity: 94%
	6 month	Remaining Capacity: 88%
	12 month	Remaining Capacity: 75%
Nominal operating temperature		25°C ± 3°C (77°F ± 5°F)
Operating temperature range	Discharge	-15°C ~ 50°C (5°F ~ 131°F)
	Charge	-10°C ~ 50°C (14°F ~ 131°F)
	Storage	-20°C ~ 50°C (-4°F ~ 131°F)
Float charging voltage(25°C)		13.50 to 13.80V Temperature compensation: -18mV/°C
Cyclic charging voltage(25°C)		14.10 to 14.40V Temperature compensation: -30mV/°C
Maximum charging current		40A
Terminal material		Copper
Maximum discharge current		1600A(5 sec.)
Designed floating life(20°C)		15 years

- ◆ Gelled electrolyte technology;
- ◆ PVC separator;
- ◆ Recognized by UL & CE;
- ◆ ABS container.

**Constant Current Discharge Characteristics (A, 25°C)**

F.V/TIME	15min	30min	60min	2h	3h	4h	5h	6h	8h	10h	20h	48h	120h
9.60V	270	186	116	68.0	48.0	37.8	31.6	27.0	21.0	18.7	10.2	---	---
9.90V	264	183	115	67.6	47.6	37.6	31.4	26.8	20.8	18.7	10.2	---	---
10.2V	254	177	112	67.0	47.4	37.2	31.2	26.6	20.8	18.6	10.2	4.46	---
10.5V	246	173	110	66.0	47.0	37.0	31.0	26.4	20.6	18.5	10.0	4.43	1.84
10.8V	232	166	106	64.4	45.6	35.8	30.0	25.6	20.0	18.4	10.0	4.43	1.84

**Constant Power Discharge Characteristics (Watt, 25°C)**

F.V/TIME	15min	30min	60min	2h	3h	4h	5h	6h	8h	10h	20h	48h	120h
9.60V	3014	2124	1340	792	566	446	376	320	250	224	123	---	---
9.90V	2940	2082	1320	786	564	444	374	318	250	224	123	---	---
10.2V	2832	2018	1288	780	560	440	370	316	248	224	123	53.5	----
10.5V	2736	1970	1262	768	556	438	368	314	246	222	121	53.2	22.2
10.8V	2592	1898	1222	748	538	424	358	304	238	220	121	53.2	22.0

Note: The above characteristics data can be obtained within three charge/discharge cycles.

**Dimensions**

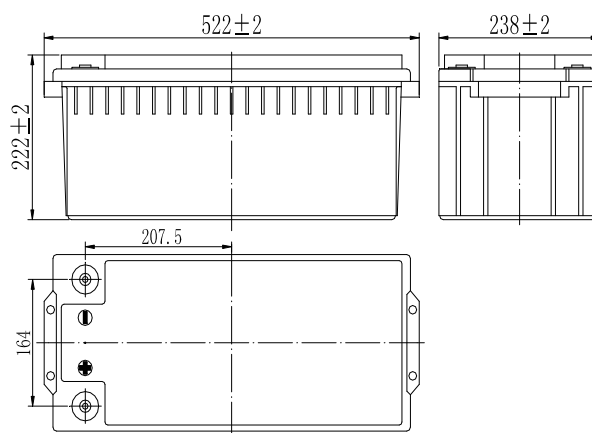

**Terminal**

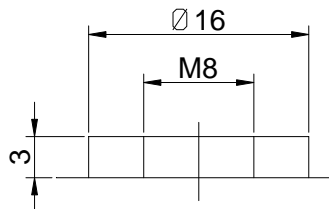

Terminal T11

**Discharge Characteristics(25°C)**

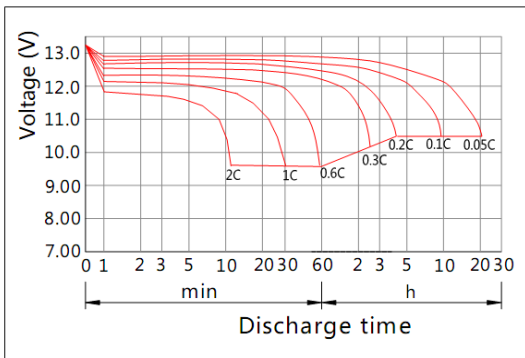

**Charging Characteristics(25°C)**

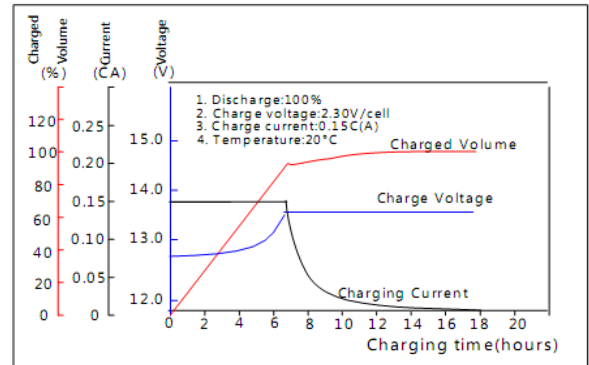

**Effect of Temperature on Capacity**

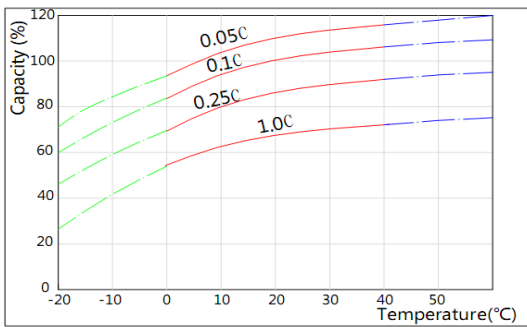

**Self-discharge Characteristics**

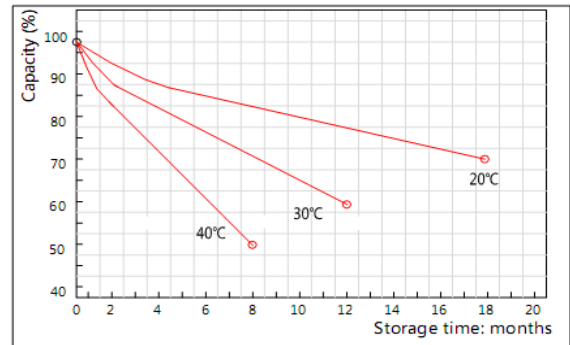

**The Relationship for Open Circuit Voltage and Residual Capacity (25°C)**

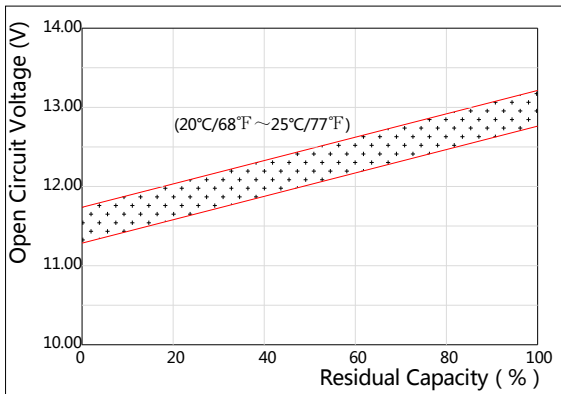

**The Relationship for Charging Voltage and Temperature**

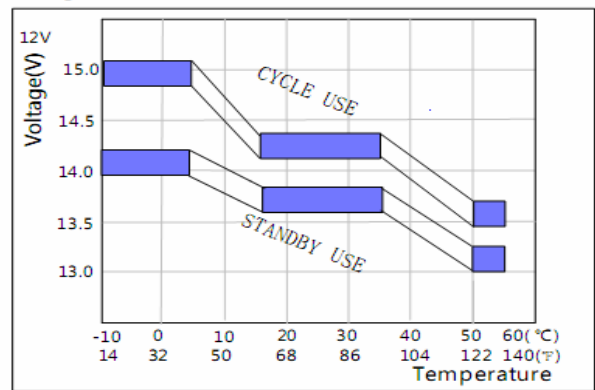

**Floating Life on Temperature**

